

Notes:
 1. Zoning: A-1, Agricultural.
 2. All Lots shall be serviced by public sanitary sewers and water
 3. Owner and Developer: David J. Clinton & Co. Inc.
 813 Broadview Dr.
 Fairfield, Ohio 45014

Acreage: Block A: 37 Lots
 Block B: 37 Lots

PRELIMINARY PLAT
PROVIDENCE MANOR SUBDIVISION SEC. 5, BLKS A, B & C
 SECTION 6 1/2 R2 UNION TOWNSHIP
 BUTLER COUNTY, OHIO

SCALE: 1"=100'

DATE: JAN. 1987

Revised: 3/30/87

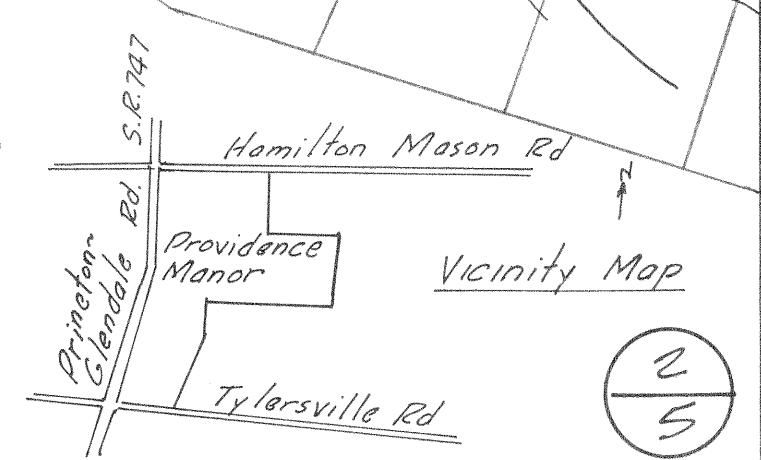

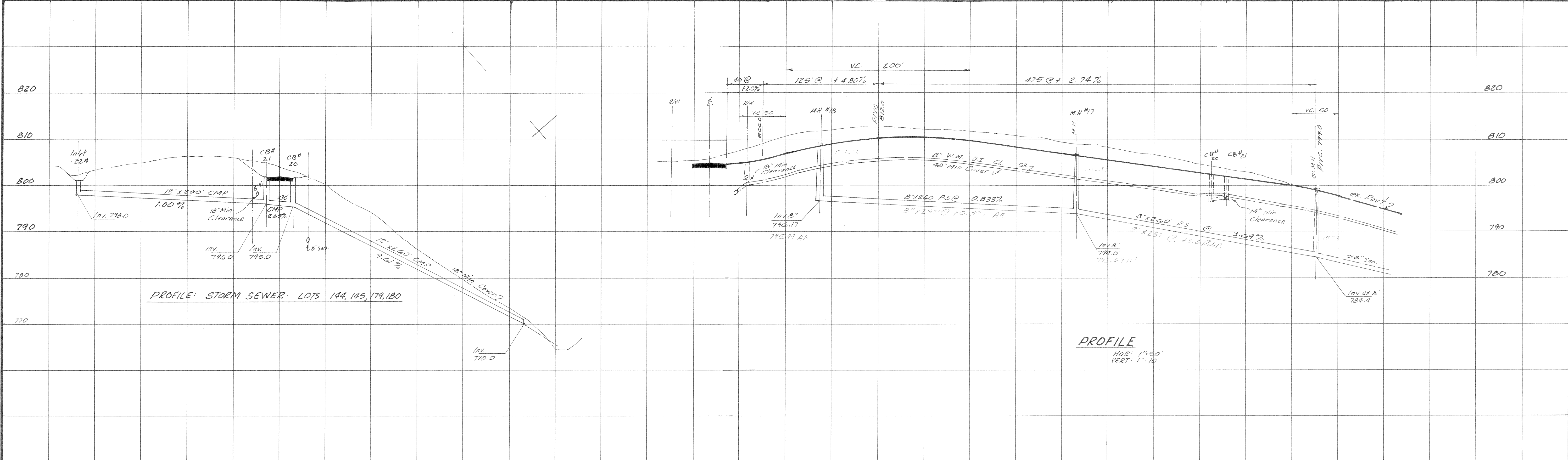
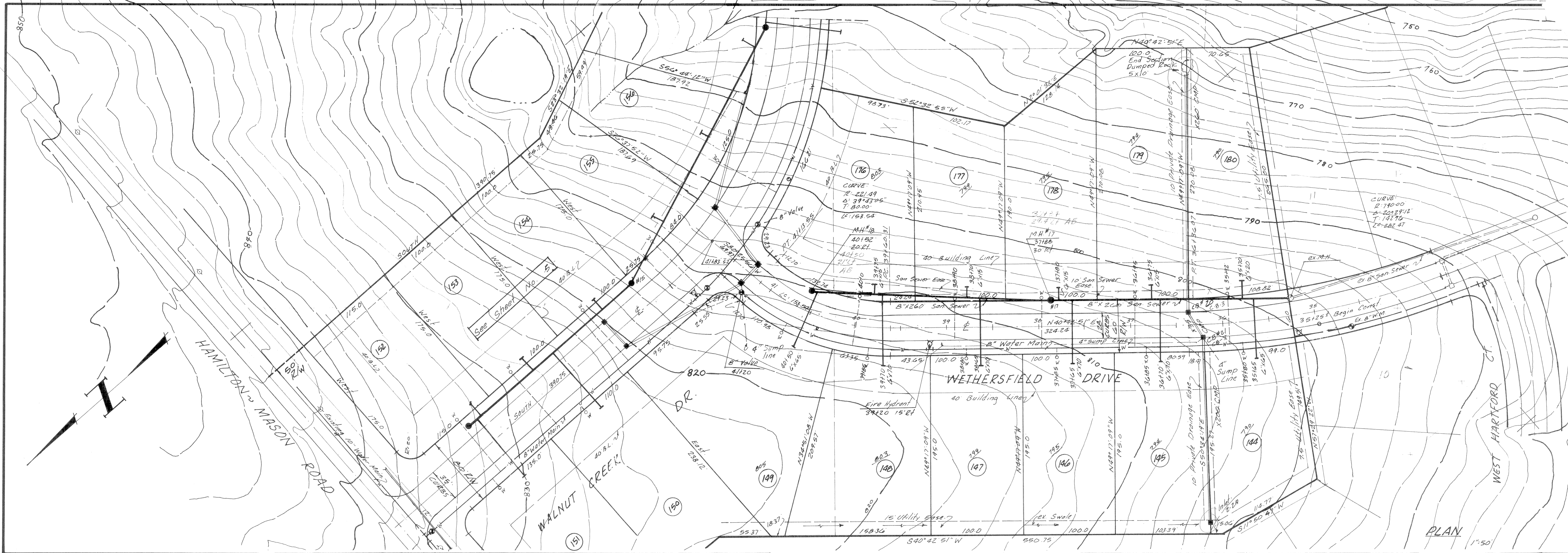

WETHERSFIELD DRIVE Sta 35125 to 41483.52
 PROVIDENCE MANOR SUBDIVISION SEC. 5 BLK. B
 SECTION 6 1/2 P. 2 UNION TOWNSHIP
 BUTLER COUNTY, OHIO
 SCALE: AS SHOWN APRIL 1987

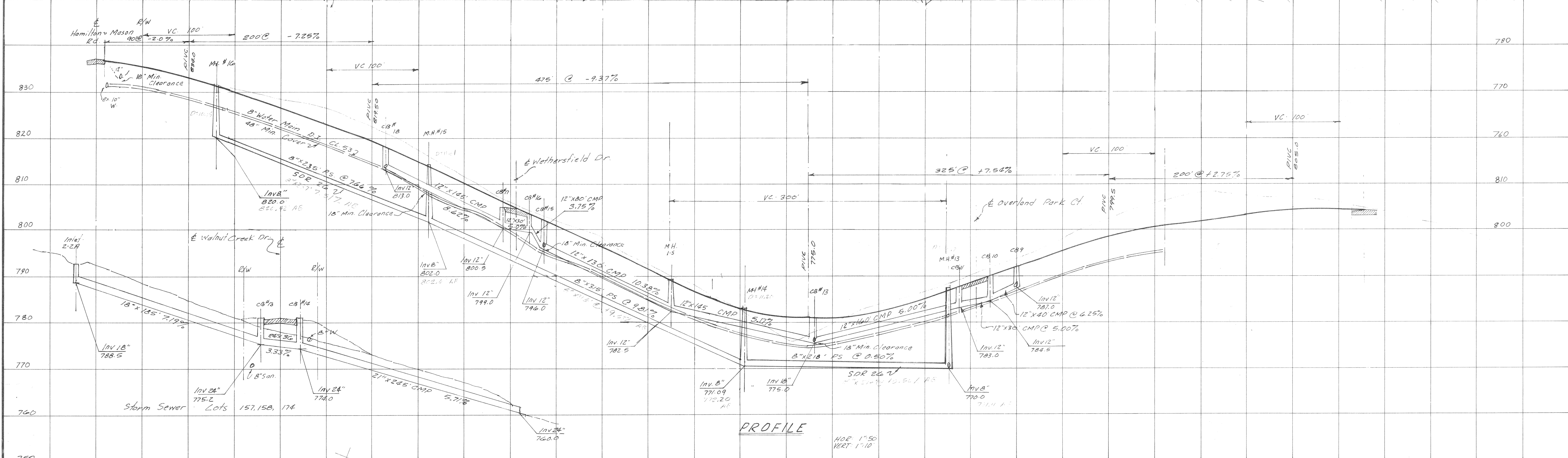
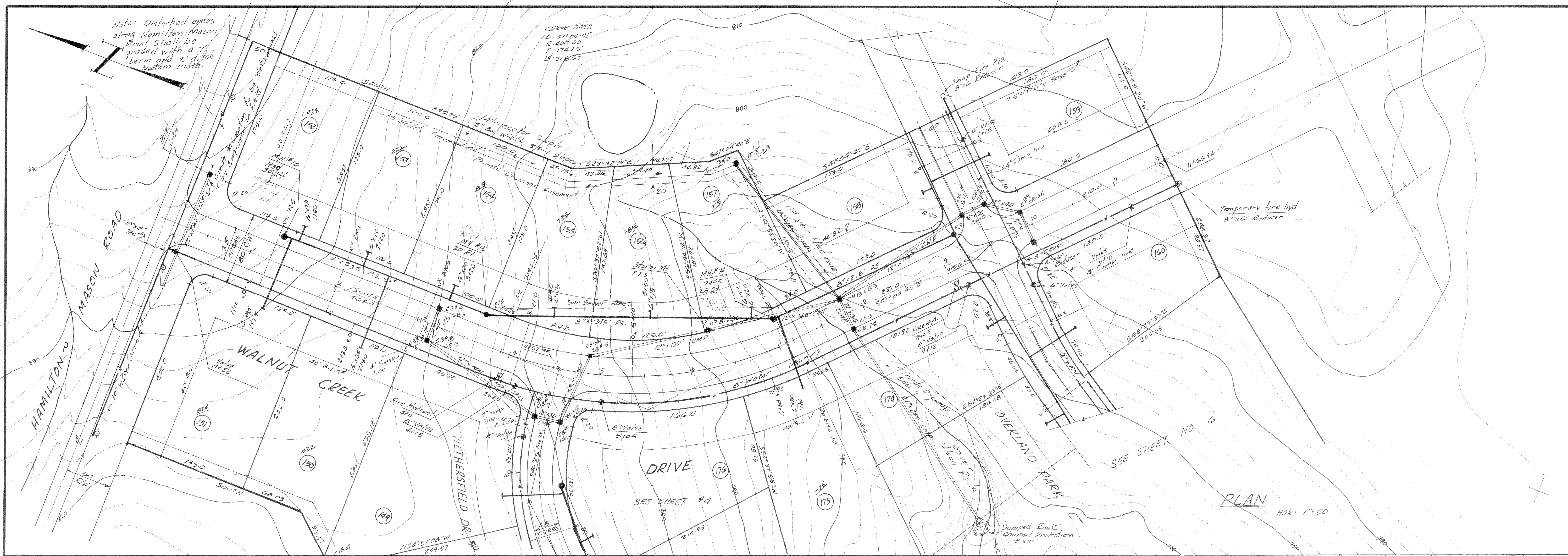

WALNUT CREEK DRIVE STA 010 TO 1146.42
 PROVIDENCE MANOR SUBDIVISION SEC 5 BLK 'A'
 SECTION 6 T. 2 R. 2 BUTLER COUNTY, OHIO UNION TOWNSHIP
 SCALE: AS SHOWN
 ARI

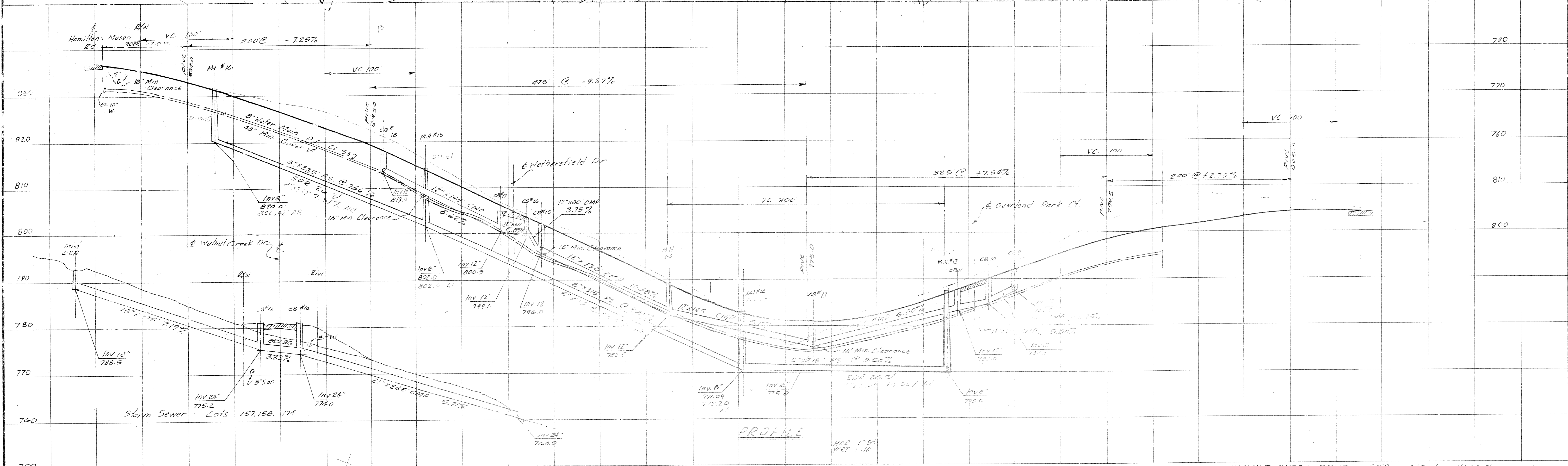
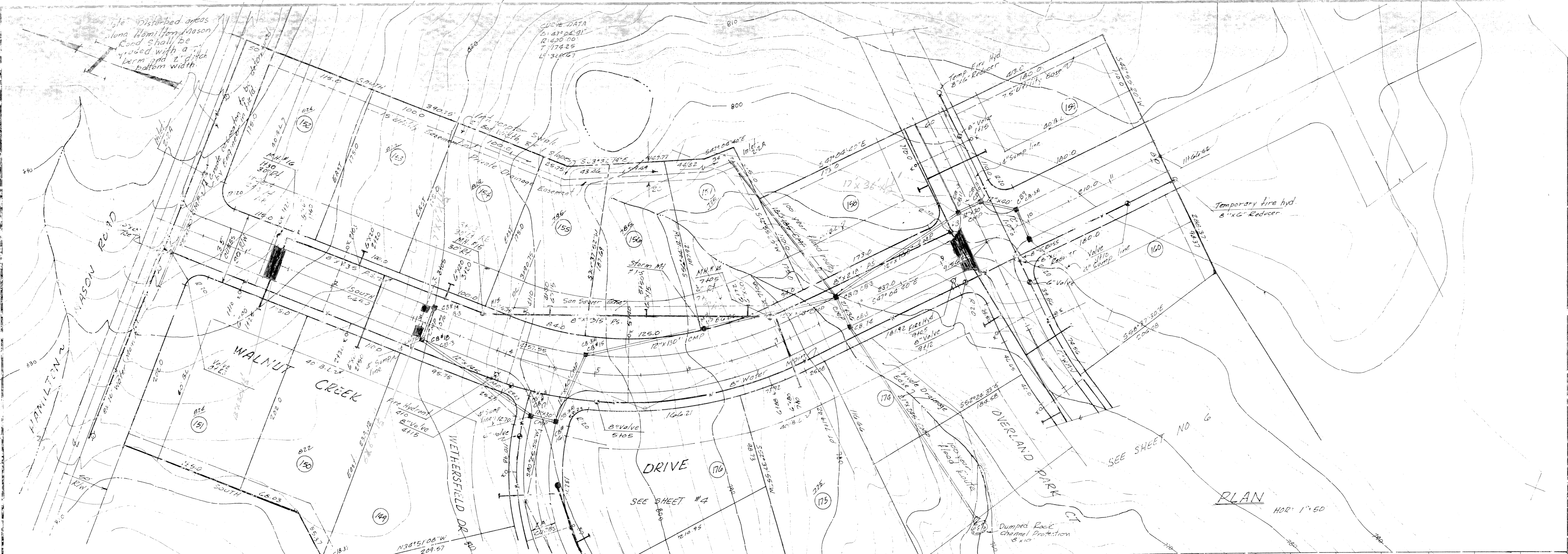

WALNUT CREEK DRIVE: STA 0+00 TO 11+66.92
 PROVIDENCE MANOR SUBDIVISION SEC 6, 7, 8 UNION TOWNSHIP
 BUTLER COUNTY, OHIO
 SCALE: AS SHOWN
 ARI



NOTE:
LOCATION OF ALL EXISTING UTILITIES
TO BE DETERMINED IN THE FIELD
PRIOR TO WORK BEGINNING ON THE
WATER MAIN.

NOTE:
Lower 3/4" Water
Services as needed
to avoid conflicts
with storm with
Min. 4' Cover.

MINIMUM SERVICE LEVELS

181 = 791.5	192 = 757.0
182 = 790.5	193 = 766.0
183 = 789.0	194 = 776.0
184 = 788.5	195 = 781.5
185 = 788.0	196 = 786.0
186 = 786.5	197 = 787.5
187 = 783.0	198 = 788.5
188 = 780.0	199 = 789.0
189 = 775.0	200 = 790.5
190 = 765.0	201 = 791.5
191 = 757.0	

NOTE:
18" min. vertical clearance OD to OD
to be maintained between
later main and Storm & Sanitary
Sewers @ Crossovers

SCALE
HORIZONTAL 1" = 50'
VERTICAL 1" = 10'

PROFILE "A"

PROFILE "C"

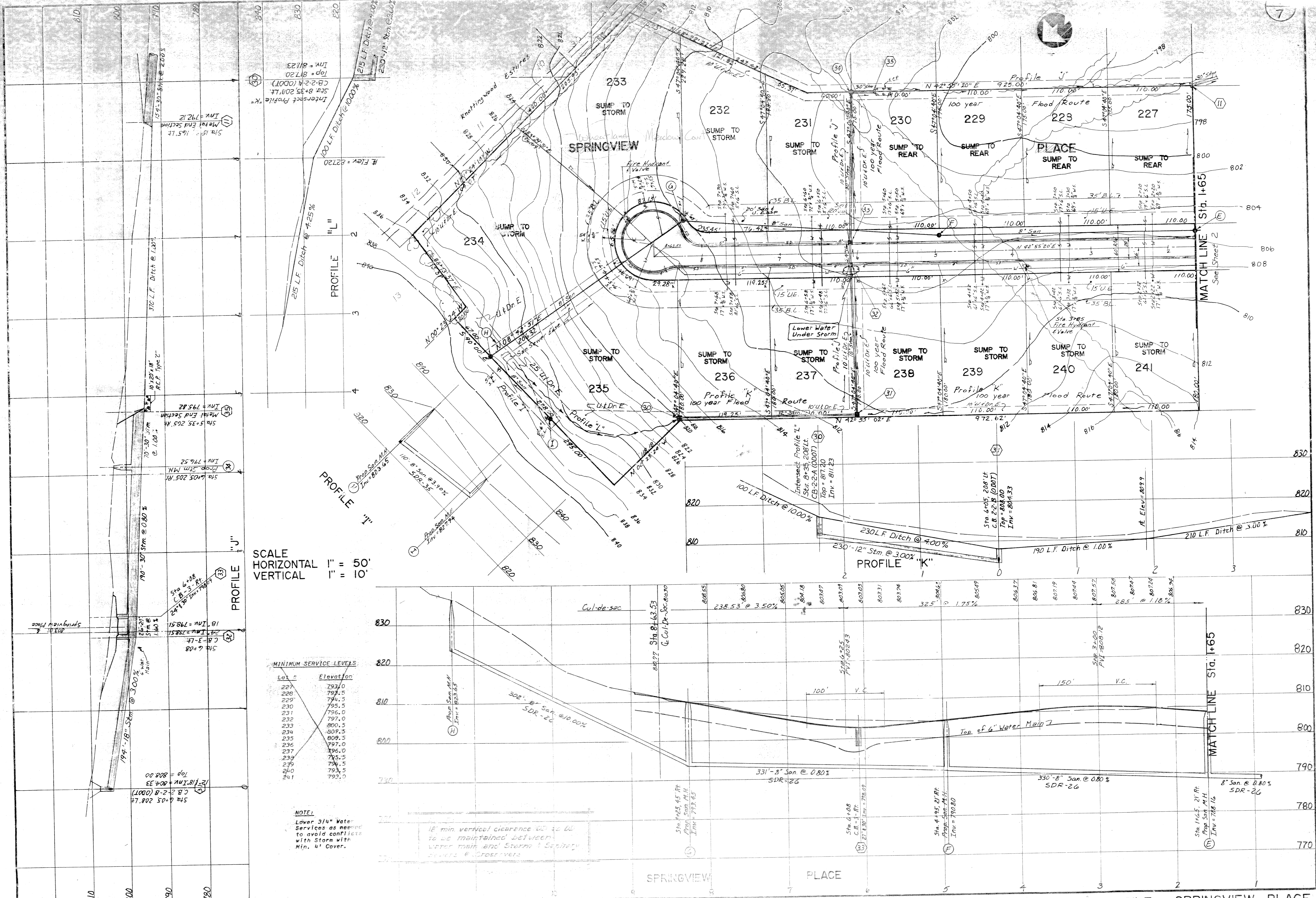

SCALE
 HORIZONTAL 1" = 50'
 VERTICAL 1" = 10'

Lot #	Elevation
227	793.0
228	794.5
229	794.5
230	795.5
231	796.0
232	797.0
233	800.5
234	809.5
235	809.5
236	797.0
237	796.0
238	795.5
239	794.5
240	793.5
241	793.0

NOTE:
 Lower 3/4" Water Services as needed to avoid conflicts with Storm with Min. 4' Cover.

18" min. vertical clearance to be maintained between water main and Storm & Sanitary Sewers & Crossovers.

PLAN & PROFILE SPRINGVIEW PLACE

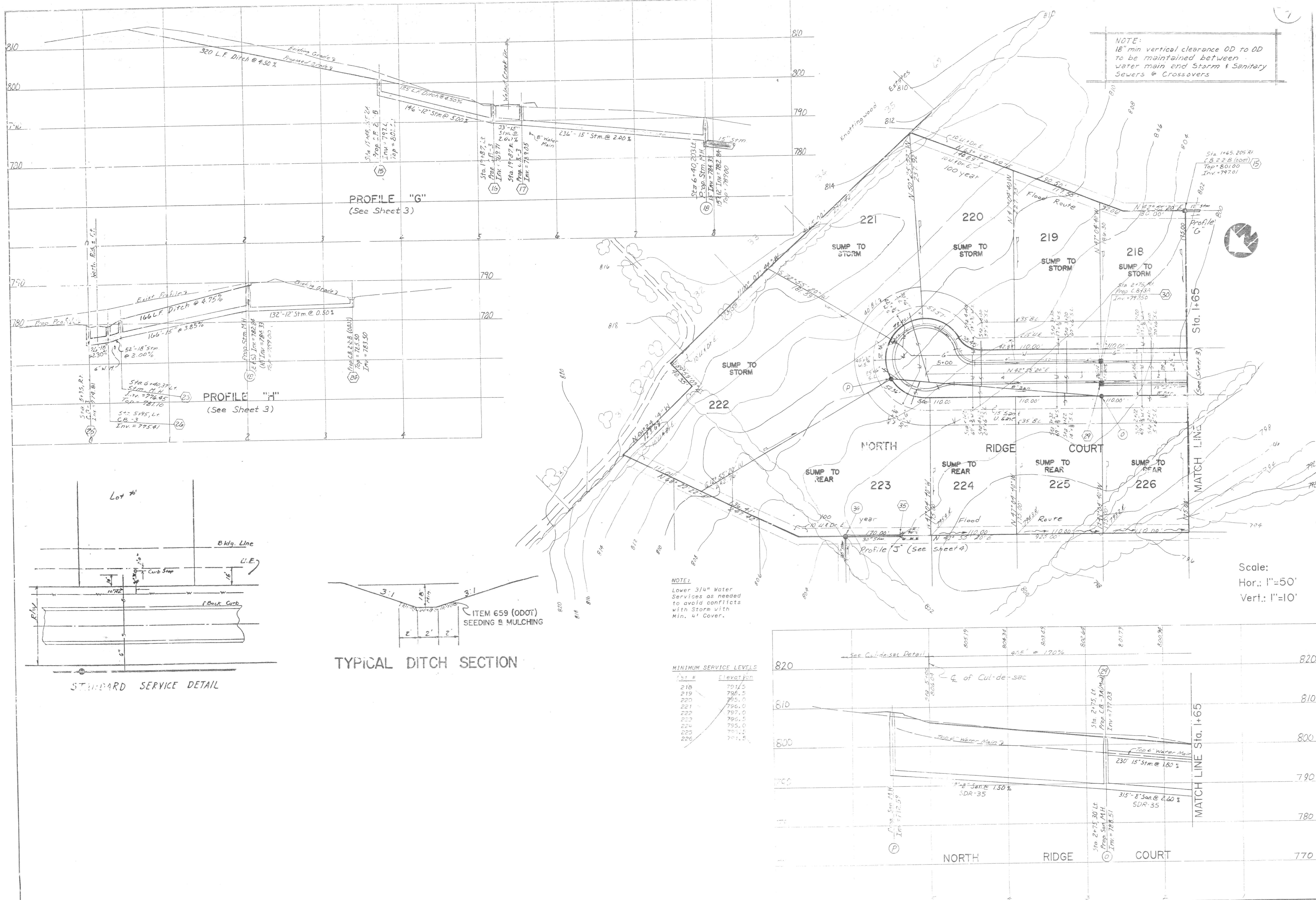

NOTE:
18" min vertical clearance OD to OD
to be maintained between
water main and Storm & Sanitary
Sewers @ Crossovers

PROFILE "G"
(See Sheet 3)

PROFILE "H"
(See Sheet 3)

NOTE:
Lower 3/4" Water
Services as needed
to avoid conflicts
with Storm with
Min. 4' Cover.

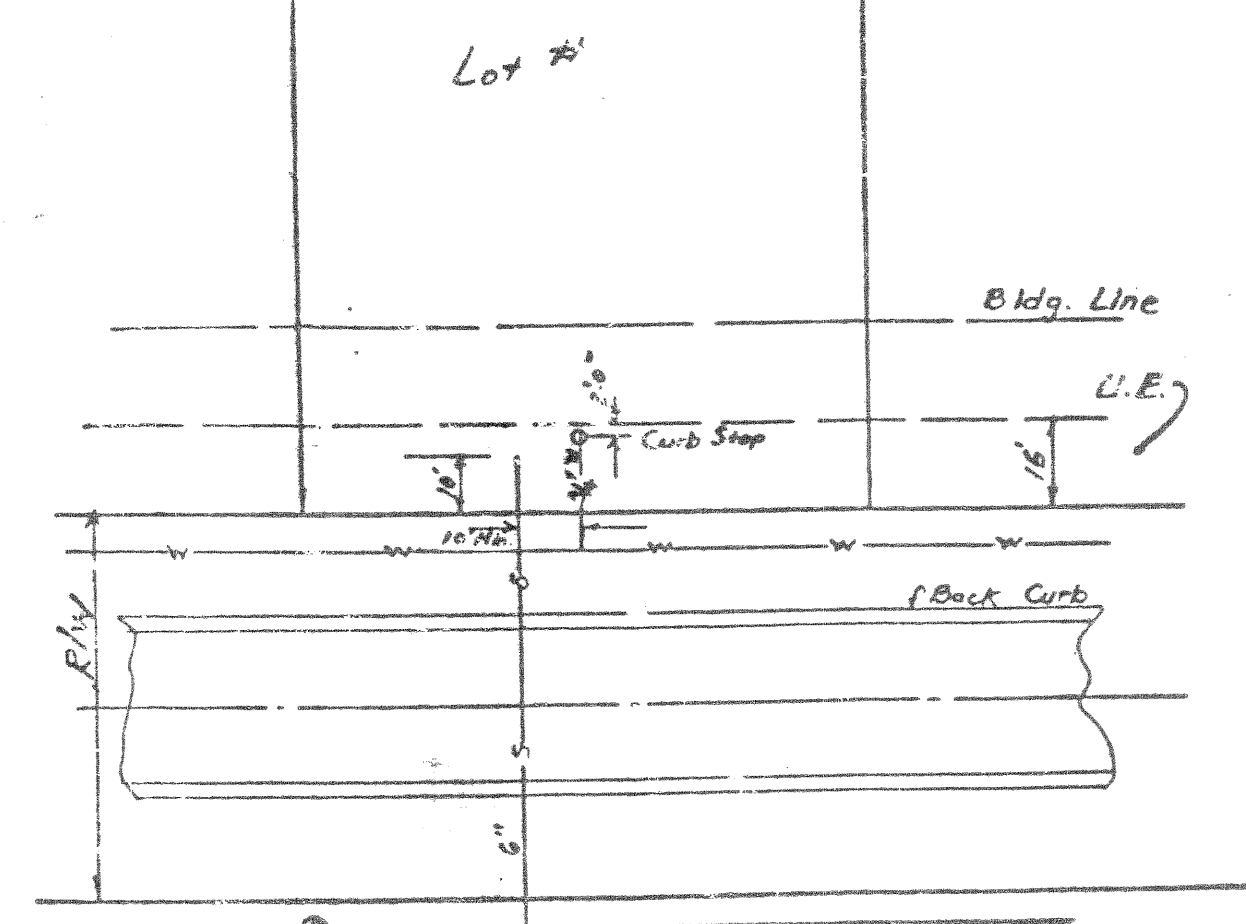
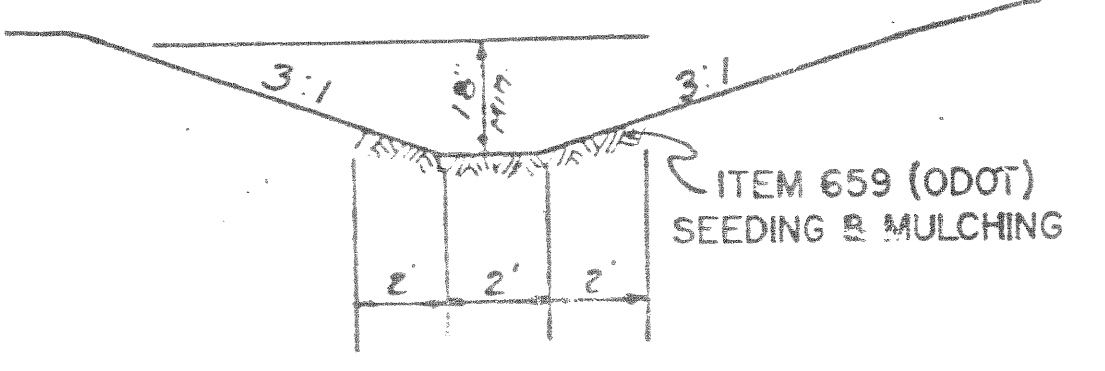

MINIMUM SERVICE LEVELS

Sta #	Elevation
218	791.5
219	795.5
220	795.0
221	796.0
222	797.0
223	796.5
224	795.0
225	791.5
226	791.5

Scale:
Hor.: 1"=50'
Vert.: 1"=10'